



Prover Leak Detector Kit Installation and Operating Manual

P: 602.233.9885
F: 602.233.9887
E: sales@flowmd.com
W: www.flowmd.com

Table of Contents

Introduction	3
Safety Notes	3
Theory of Operation	3
Tools Required	3
Leak Detector Main Components	4
Mounting (Initial Installation)	5
Operations	6
Storage	11

Introduction

The Prover Leak Detector Kit manufactured by Flow Management Devices, LLC (Flow MD)™ is a maintenance tool to assist in identifying damage/wear to internal sealing components. Use of this device should be performed by only trained and qualified personnel. This manual will cover the installation and operation of the leak detector kit in detail. This leak detection system is intended to give a general idea of the condition of the piston seals. It does not guarantee prover performance.

Safety Notes-

- Lock out/tag out any energy source by qualified personnel.
 - Energy source – Any source of electrical, mechanical, pneumatic, chemical, thermal or other energy.
- Liquids that are compressed gases e.g. propane, ethane etc, can flash off if system is vented or PSV device opens. Prover drive system and leak detector can suddenly move with great force.

Theory of Operation

The leak detector works by measuring the piston displacement and time. The provers piston is pushed downstream effectively generating a pressure differential. Movement of the piston is an indication that liquid has moved from the downstream to upstream end of the prover. Measuring the displacement of the piston and the time it occurs establishes a leak rate. Note: It is assumed that all movement of the piston is a result of leak by the piston inside prover. Leaks elsewhere in the system will falsely indicate a piston seal leak. Temperature must be stable to ensure movement is not due to thermal expansion/contraction.

The basis of the allowable leak rate is determined by considering a leak that is very small (i.e. near the uncertainty of the prover volume) that would occur at a very low flow rate (i.e. turn down ratio > 50). During normal proving operations a leak of this size would be unmeasurable as it is a small fraction of the measurement uncertainty.

Tools Required

- 1) Leak Detector Kit
- 2) 7/8" wrench (socket, ratchet on drill drive-optional)
- 3) Means to measure elapsed time. Clock, watch, phone or stopwatch.

Leak Detector Kit Main Components

Verify all components in the kit.



Lever Torque Leak Detector



Spring Cylinder Assembly



Bar Leak Detector Mounting



Clip Leak Detector



Screw Hex Head Cap 1/2-13x1



Screw Hex Head Cap 3/8-16x1



Nut Hex 3/8-16

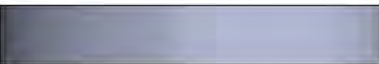

Velcro Retention Straps

Installation

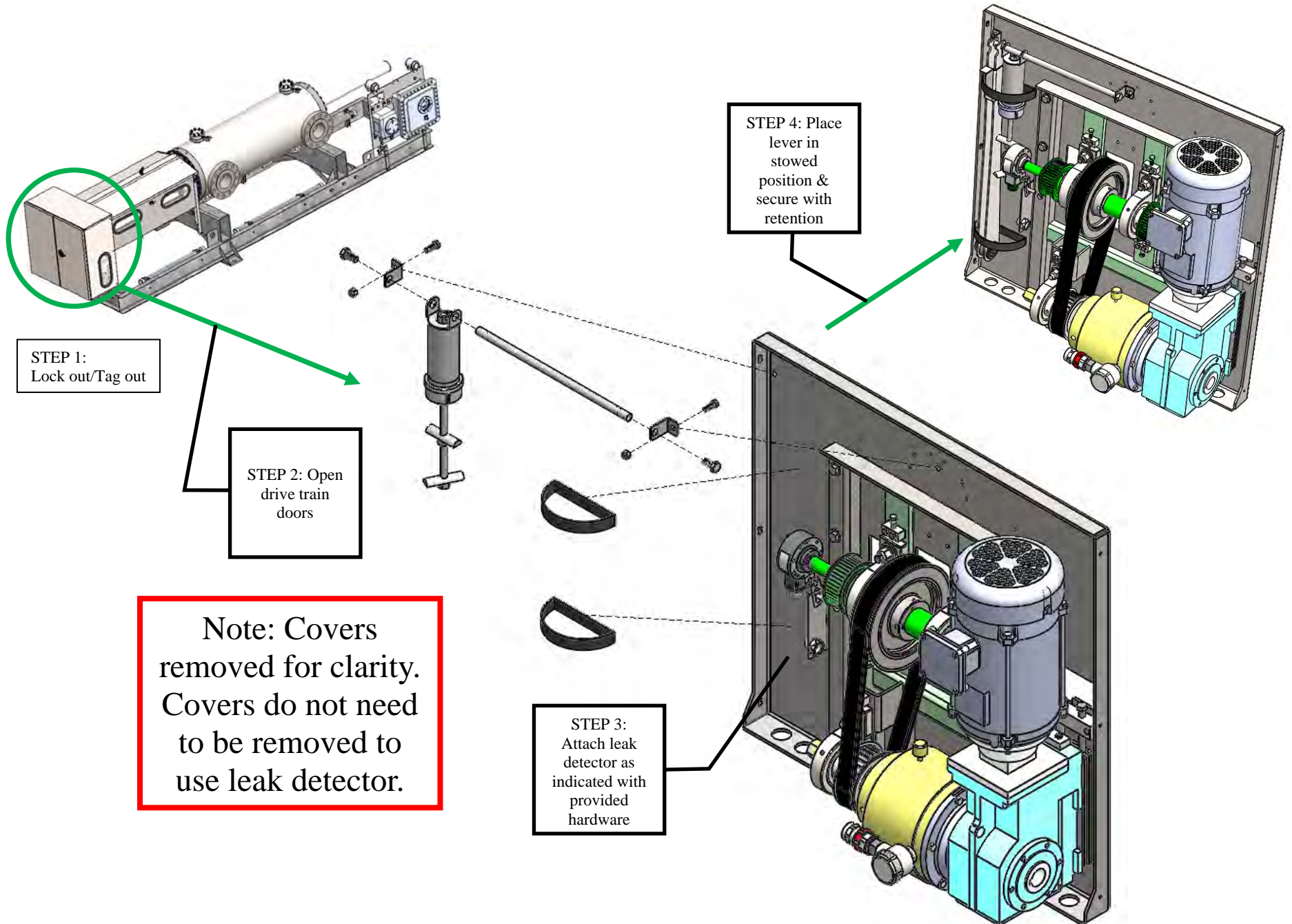

Operation

Safety procedure reminder:
Lock out/tag out electrical
supply & all inlet/outlet
process connections

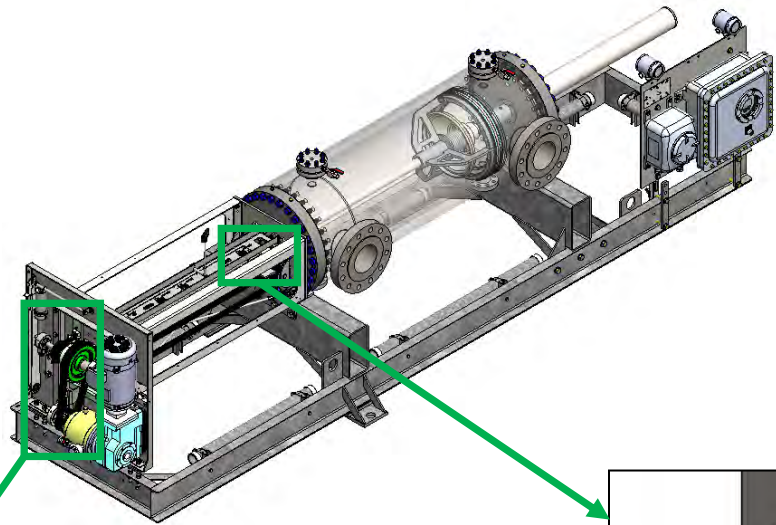

STEP 1: If possible start with prover piston downstream (i.e. shuttle at shocks)

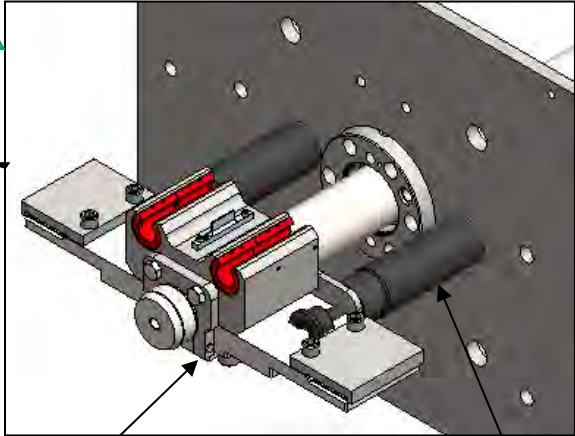

shuttle

shocks

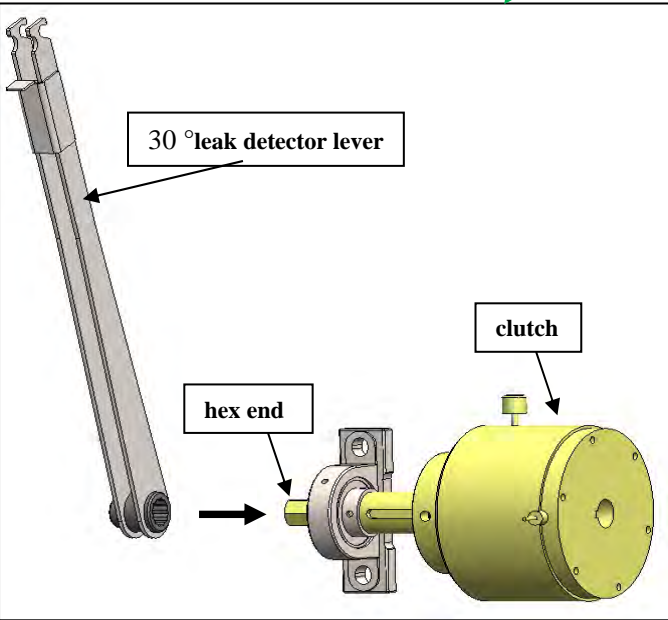

STEP 2: Remove lever from mounting bar and attach the clutch as illustrated

Note: Covers removed for clarity.

STEP 3: With lever, pull piston upstream to the desired test location within the measurement bore i.e. shuttle between volume switches V_3 & V_1

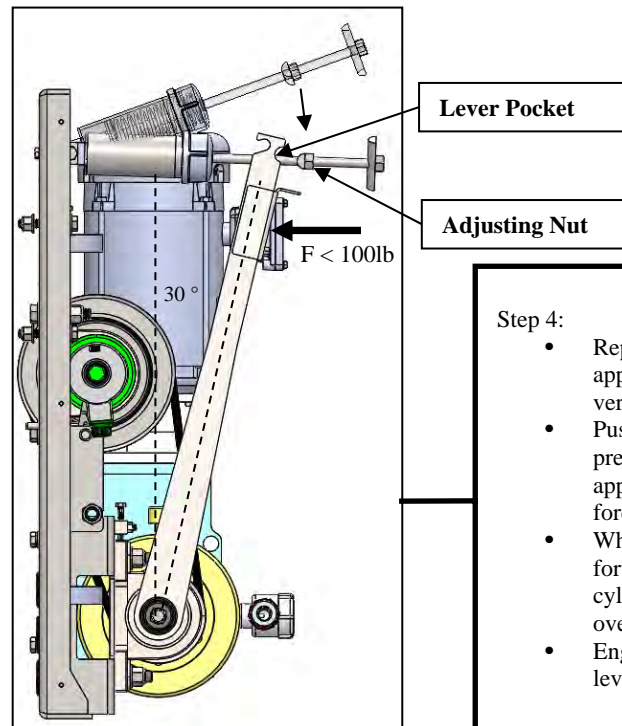
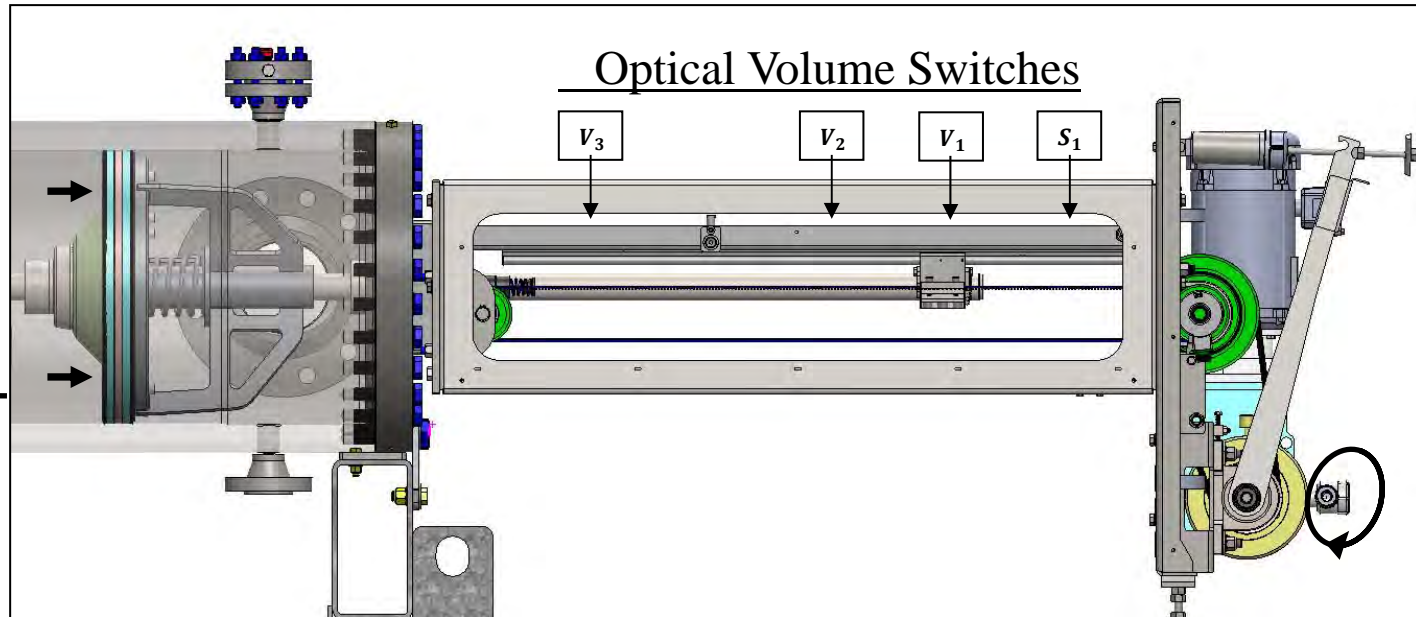

- Step 4:
- Reposition lever at approximately 30° from vertical
 - Push lever forward to preload system (do not apply more than 100lb of force on lever)
 - While holding lever forward, pull on spring cylinder handle and swing over the top of lever
 - Engage adjusting nut to lever pocket

Note: Applying excessive force on lever will cause belt to skip, possibly damaging the belt

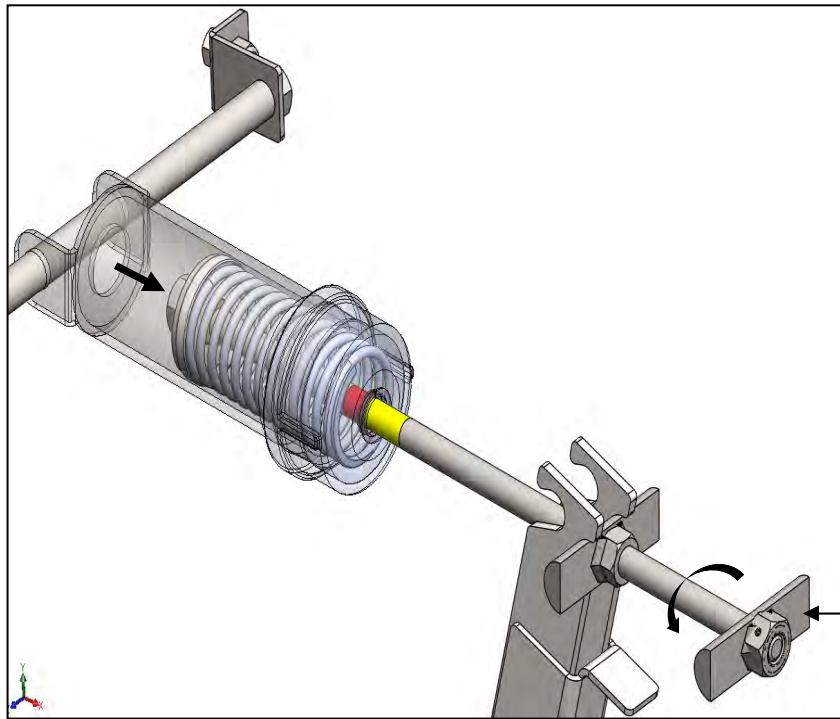

STEP 5: Rotate adjuster counterclockwise until all of yellow indicator band is exposed (start of red band)

Note: Do not adjust beyond the yellow band, the red band indicates the limit of system.

adjuster

STEP 6: Lever must have minimum 1" clearance to spring housing to allow for free forward movement of arm

STEP 7: Begin measuring elapsed time

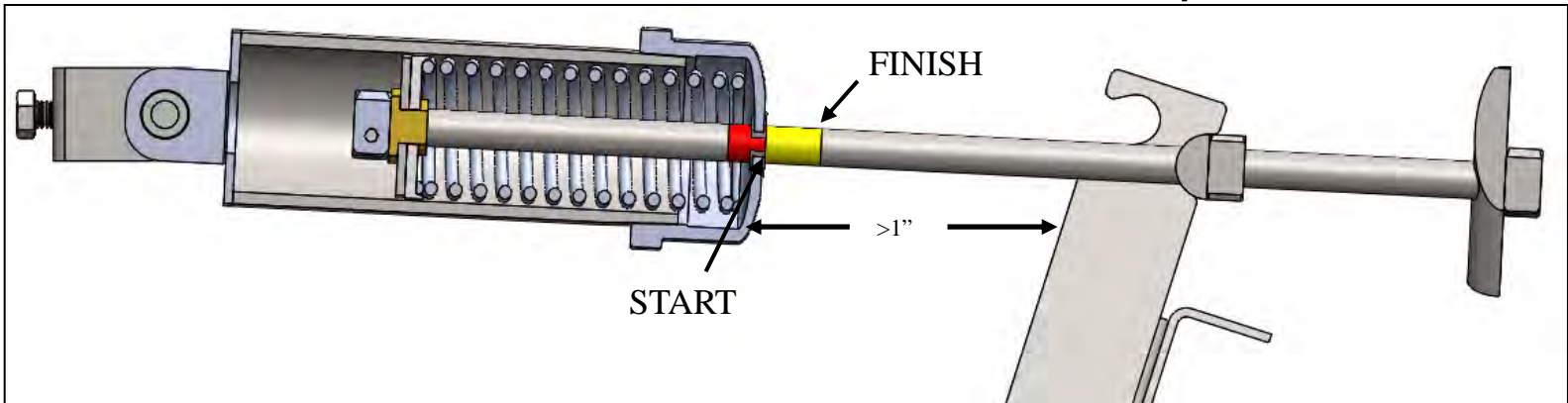

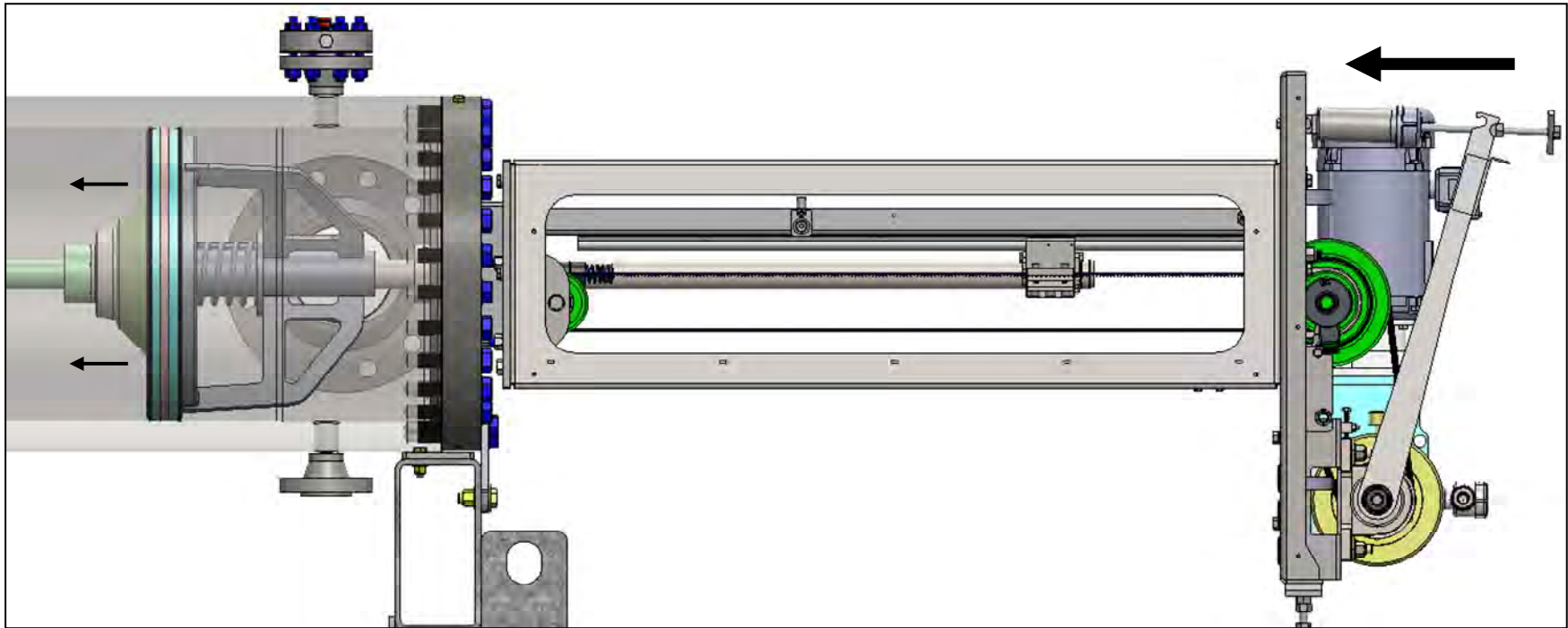

STEP 8: If a leak is occurring in the system, the spring will slowly expand. The piston will travel forward, and the yellow indicator will travel inside the spring cap. If the yellow indicator goes into the spring cap within the time frame given in table 1, piston maintenance is recommended

Note: Verify there are no other leak paths as this will give a false result.

PROVER	TIME OF TEST
FMD 015-090	10 minutes

TABLE 1: ALLOWED DISPLACEMENT VS TIME

After 10 minutes test example

Yellow indicator fully inside = test failure

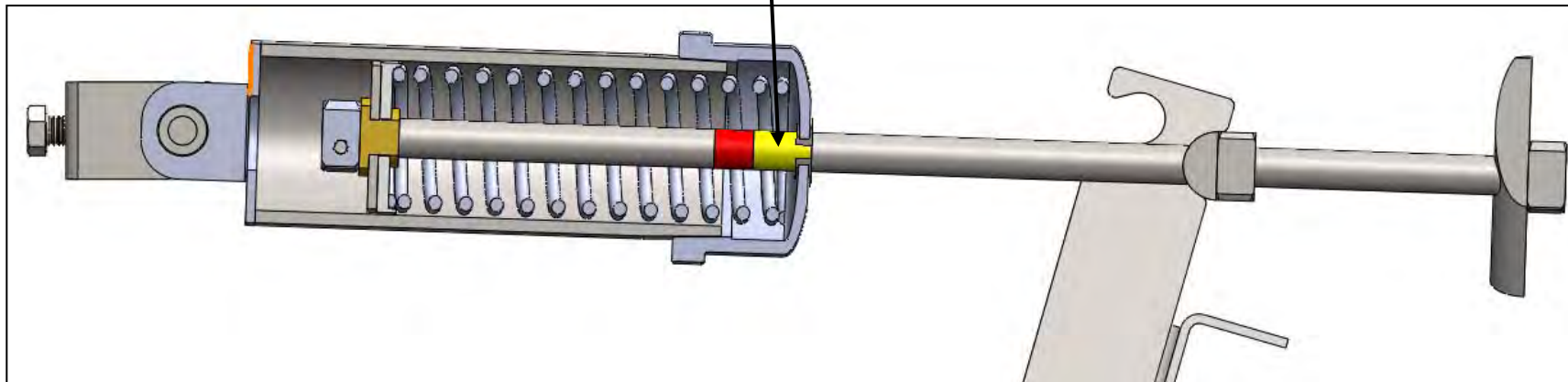

Yellow indicator partially inside = test pass

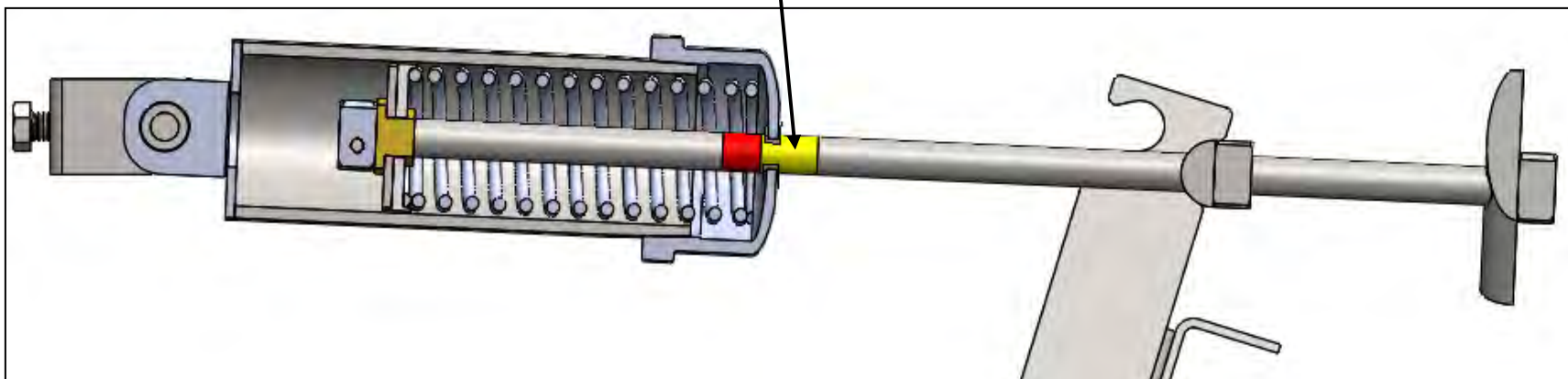

Storage

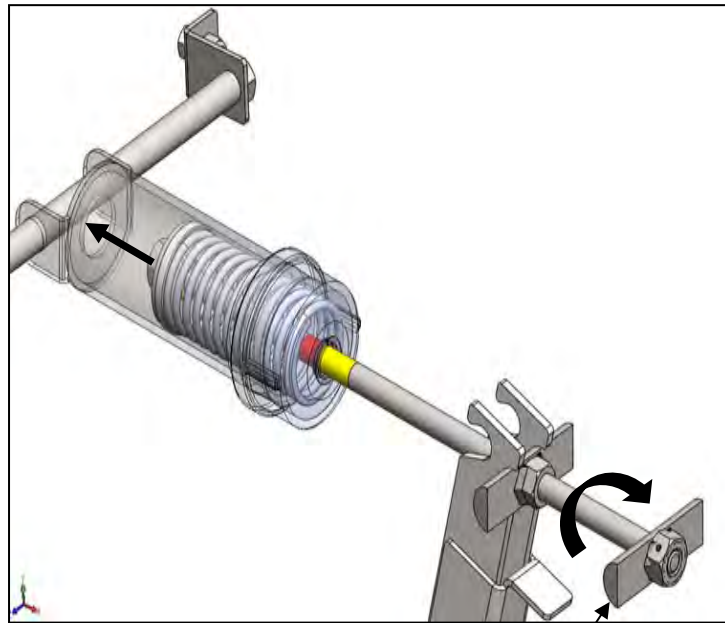

STEP 9: Rotate adjuster clockwise until the lever is free to move

adjuster

STEP 10: Once the lever is free to move, lift the cylinder and remove the lever from hex end

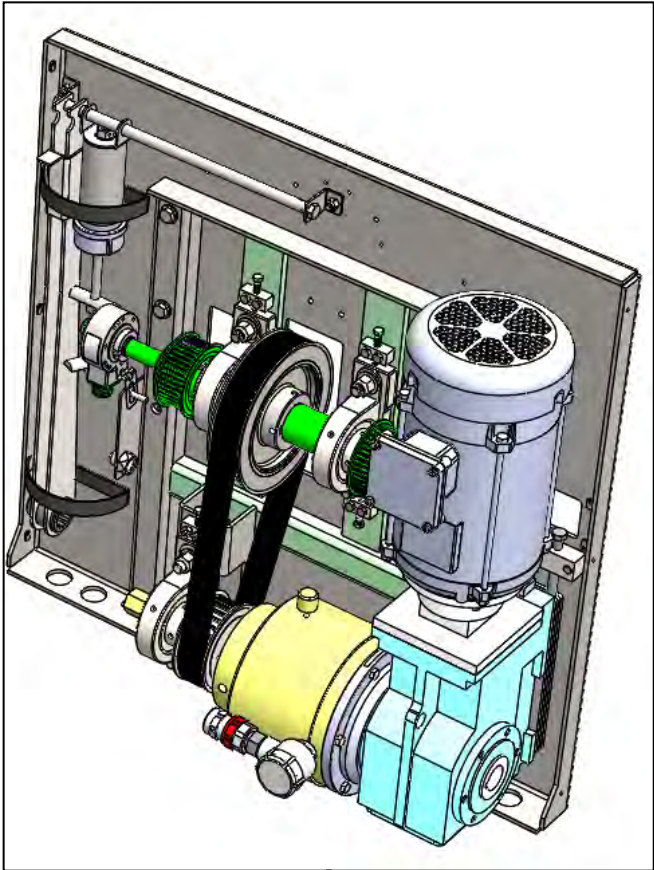
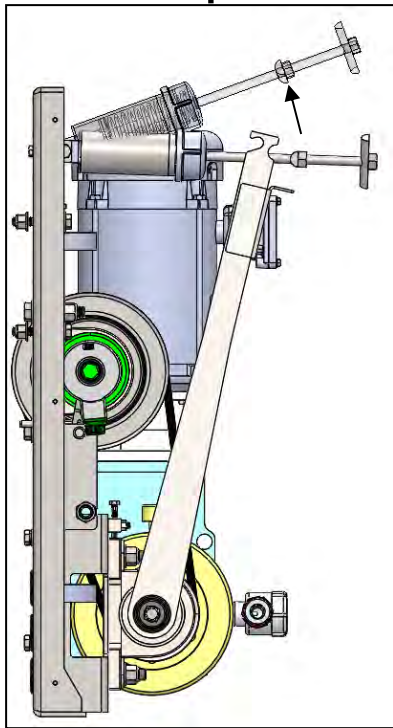

STEP 11: Place lever in stowed position & secure with retention straps as illustrated